

## CBD20J-B Semi-electric Pallet Truck

### Characteristics:

1. The truck is simple and dexterous, with small turning radius and small weight. It is suitable for ultra-narrow channel operation.
2. The truck has compact and reliable structure. The oil pipeline and line are wrapped in the truck body which is safe and beautiful and convenient for user maintenance.
3. The truck adopts integrated handle design integrating key switch and electric meter which is simple and comfortable for operation.
4. The front baffle and battery is easy to disassemble and replace.
5. Standard configuration of emergency stop switch and emergency reverse device ensure truck safety.
6. The truck is assembled with power-off braking function. The truck is braked as soon as the handle is loosened or pressed to the bottom.
7. Electromagnetic braking and motor braking are used to ensure the safety of driving.
8. Standard configuration of built-in charger is easy to charge.



## CBD20J-B

### Manufacturer's Data and Design Characteristics

Characteristics			
1.1	Manufacturer		HELI
1.2	Model		CBD20J-B
1.3	Type of operation		Pedestrian
1.4	Rated capacity	Q (kg)	2000
1.5	Lift height	h3 (mm)	200
1.6	Service weight with battery	kg	155
1.7	Load centre	c (mm)	600
1.8	Axle centre to fork face	x (mm)	944
1.9	Wheel base	y (mm)	1243
1.10	Controller		CURTIS
Wheels			
2.1	Wheels type		Polyurethane
2.2	Driving wheels size	Φ×w(mm)	Φ210×70
2.3	Loading wheels size	Φ×w(mm)	Φ80×60
2.4	wheels, number front/rear (x = driven)		1x/4
2.5	track width, rear, loading side	b11 (mm)	400/535
Dimensions			
3.1	Overall length	l1 (mm)	1620
3.2	Length to fork face	l2 (mm)	470
3.3	Overall width	b1 (mm)	550/685
3.4	Fork dimensions	s/e/l (mm)	50/150/1150
3.5	Width of forks	b5 (mm)	550/685
3.6	Lowered height	h13 (mm)	85
3.7	Min. Ground clearance	m2 (mm)	35
3.8	Height drawbar in driving position min./max.	h14 (mm)	720/1090
3.9	Aisle width with pallet 1000 x 1200 across forks	Ast (mm)	1825
3.10	Aisle width with pallet 800 x 1200 along forks	Ast (mm)	1875
3.11	Min. Turning radius	Wa (mm)	1415
Performance			
4.1	Travel speed, with/without load	(km/h)	4.2/4.5
4.2	Max. Gradeability laden/unladen	(%)	3/10
4.3	Service brake type		Electromagnetic brake
Drive and Battery			
5.1	Drive motor, output s2 60 min.	(kW)	0.75
5.2	Lift motor rating at s3 15%	(kW)	无
5.3	Battery according to din 43531/35/36 a,b,c, no		no
5.4	Battery voltage/rated capacity	(V/Ah)	24/32
5.5	Battery weight (± 5%)	(kg)	20.2
5.6	Charger specification		24V/5A
Others			
6.1	Type of drive control		DC
6.2	Sound pressure level at driver's ear	(dB(A))	≤70
6.3	Steering type		Mechanical steering

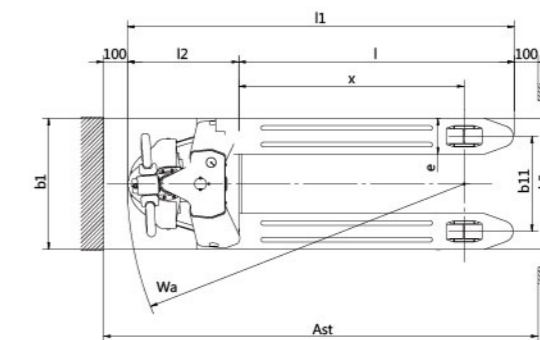
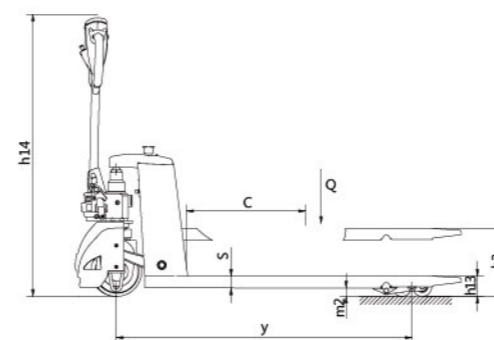

**ANHUI HELI CO., LTD.**

Add / No.668, FangXing Road, Hefei, China  
Fax / +86-511-63639966

Tel / +86-511-63639068(America); 63639258(Europe);  
63639358(Asia); 63662105(Africa & Middle East);  
63639530(Key Accounts Division); 63662105(Wheel loader)