

HELI

3-3.5 t

G3 Series 3-3.5 Tons Dual-Drive Battery Forklift Truck



- > The double motors drive the front wheel, and the power is stronger.
- > Independent steering system is configured to save energy.
- > All LED lights, more energy saving.
- > Side way to replace the battery, convenient and efficient.
- > With multiple performance modes, easy to choose driving.
- > The driver can operate the lift and tilt through the fingertip system.
- > Wet disk brake have reliable performance and free maintenance.
- > With negative braking function, parking is safer and more reliable.

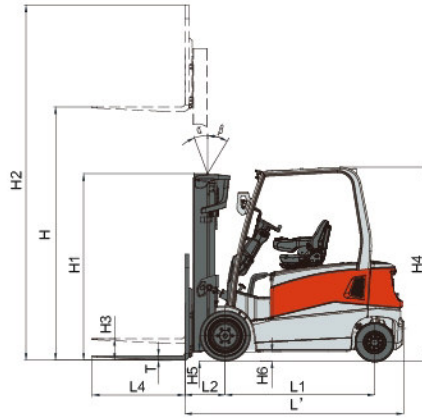

Ast: Right angle stacking aisle width
 a: Clearance
 b: Load length
 b12: Load width

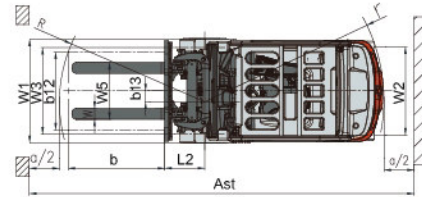

Characteristic				HELI	
1.01	Manufacturer				
1.02	Model			CPD30	CPD35
1.03	Configuration Number			GD2D	GD2D
1.04	Load Capacity/Rated Load	Q	kg	3000	3500
1.05	Service Weight Incl. Battery		kg	5310	5680
1.06	Load Centre Distance	c	mm	500	500
1.07	Power Mode			Battery	
1.08	Driving Mode			Seated	
Wheels & Tyres					
2.01	Tires			SE	
2.02	Tyre Size, Front			23x10-12	23x10-12
2.03	Tyre Size, Rear			200/50-10	200/50-10
2.04	Wheels, Number Front Rear (X=Driven Wheels)			2x/2	2x/2
Dimension Parameter					
3.01	Wheelbase	L1	mm	1750	1750
3.02	Load Distance, Centre Of Drive Axle To Fork	L2	mm	463	468
3.03	Mast/fork Carriage Tilt (Fwd./Bwd.)	α/β	°	6/8	6/8
3.04	Lift Height	H	mm	3000	3000
3.05	Lowered Mast Height	H1	mm	2155	2155
3.06	Free Lift	H3	mm	145	150
3.07	Fork Dimension	T/W/L4	mm	45x125x1070	50x125x1070
3.08	Length To Face Of Forks	L'	mm	2547	2552
3.09	Overall Width	W1	mm	1195	1195
3.10	Overhead Guard (Cab) Height	H4	mm	2260	2260
3.11	Turning Radius	r	mm	2150	2150
3.12	Ground Clearance, Centre Of Wheelbase	H6	mm	130	130
3.13	Track Width, Front	W3	mm	975	975
3.14	Track Width, Rear	W2	mm	990	990
Performance Parameter					
4.01	Travel Speed, Laden		km/h	19	18
4.02	Travel Speed, Unladen		km/h	20	19
4.03	Lift Speed, Laden		m/s	0.50	0.44
4.04	Lift Speed, Unladen		m/s	0.63	0.54
4.05	Max Gradient Performance Laden		%	21	20
4.06	Max Gradient Performance Unladen		%	29	27
Motor & Controller					
5.01	Drive Motor Rating (60 Min.)	S2	kW	8x2	8x2
5.02	Lift Motor Rating (15%)	S3	kW	25.5	25.5
5.03	Drive Motor Control Method			MOSFET/AC	
5.04	Pump Motor Control Method			MOSFET/AC	
Battery					
6.01	Battery Acc. To Din43531 / 35 /36 A, B, C			43536A	43536A
6.02	Battery Voltage, Nominal Capacity K5	U /K5	V/Ah	80/700	80/700
6.03	Battery Dimension l/w/h		mm	1028x855x754	1028x855x754

NOTE:For configuration number,2-ZAPI Controller.

* Our products are subject to Improvements and changes without notice.



ANHUI HELI CO., LTD.

Add / No.668, FangXing Road, Hefei, China
 Fax / +86-551-63639966

Tel / +86-551-63639068(America); 63639258(Europe);
 63639358(Asia); 63662105(Africa & Middle East);
 63639530(Key Accounts Division); 63662105(Wheel loader)