

## CPD15/18/20/25 /30/35/38

A3H4-M A5H4-S/M A5XH4-S



*H4* SERIES

### 1.5-3.8 t

H4 Series Battery Powered  
Counterbalance Forklift truck



**ANHUI HELI CO., LTD.**

Add / No.668, FangXing Road, Hefei, China

Fax / +86-551-63639966

Tel / +86-551-63639068(America); 63639258(Europe); 63639358(Asia);  
63662105(Africa & Middle East);



LinkedIn



YouTube



Facebook

FL(HH)001EN  
Design&Print:Fokell Printing / 20221010

# Lead & Lithium Are Ready To Go.

H4 series 1.5-3.8 t battery powered counterbalance forklift truck emerge as the times require

People oriented design concept / inheritance family design concept  
seek breakthrough in a appearance / showing dynamic charm in design details



Comfort and energy saving

01~02

The user experience is fully considered, and the superior operating space design provides high driving comfort.



Stable and Reliable

03~04

CAE analysis, component bench test and whole truck strengthening test are used to ensure reliability.



Intelligent security

05

Intelligent control and protection improve the safety of drivers.



Convenient maintenance

06

More convenient maintenance operation improves the maintenance efficiency of after-sale services.

# Comfort and energy saving

The user experience is fully considered, and the superior operating space design provides high driving comfort.

Wide view mast design, wide front view

The big handle and the super spacious cab design are suitable for people of different heights.

Steering wheel start steering (optional)

P, E, S three speed regulation

- P — Powerful
  - E — Economics
  - S — Energy saving
- Multi gear performance mode can be freely selected according to actual working conditions.



The whole truck is equipped with LED lighting system as standard, with high brightness, long service life and more energy saving

Reversing horn handle (s optional, M standard)



Semi enclosed shock-absorbing seat offers high comfort.



Electric special pattern tyre has low driving damping.

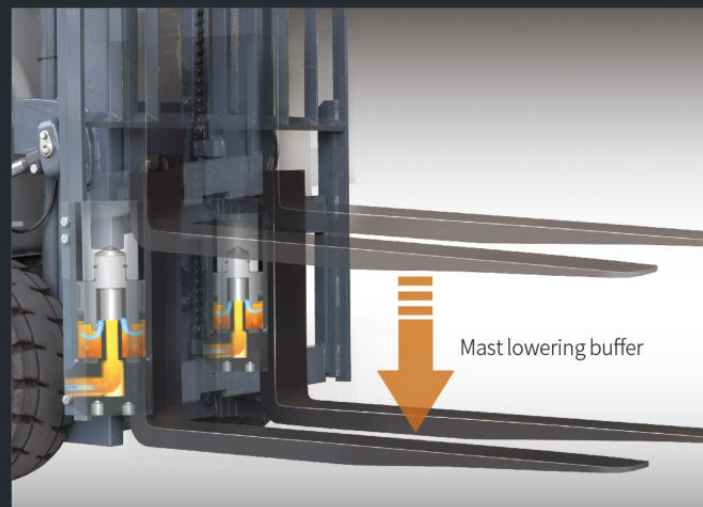

Mast lowering buffer

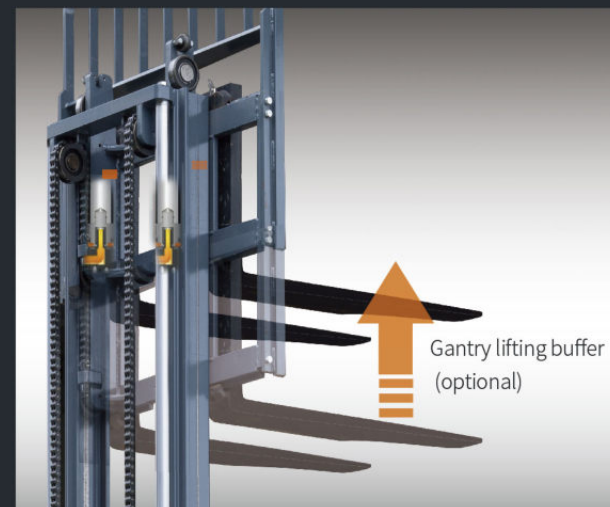

Gantry lifting buffer (optional)

Right set operating valve stem offers good operation comfort.

Intelligent color screen instrument offers more friendly human-computer interaction.



Graphical interface design / Chinese fault display / integrated handheld unit function / optional integrated vehicle networking function



Full package design of instrument panel; Water cup holder, mobile phone storage space, USB interface (optional for S, standard for M)

# Stable and Reliable

CAE analysis, component bench test and whole truck strengthening test are used to ensure reliability.

## Reliable components

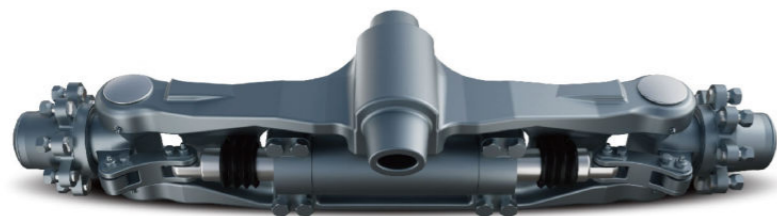

### Steering axle:

Cast axle body, tapered roller bearing

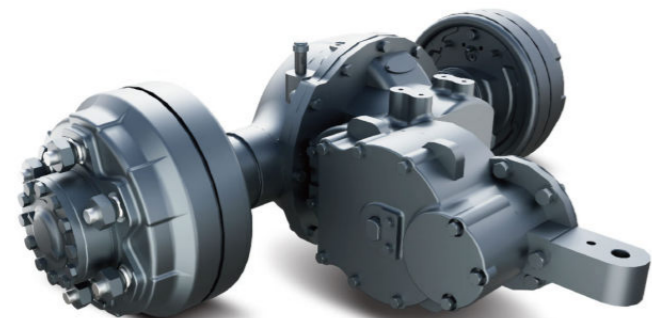

### Drive axle:

integral brake drum, integral cast axle housing, half shaft oil seal design, high-precision gear with large coincidence



### Mast:

Borrowing the main components of mature mast of internal combustion forklift truck

Sheet metal stamping side cover

All metal anti-skid pedal

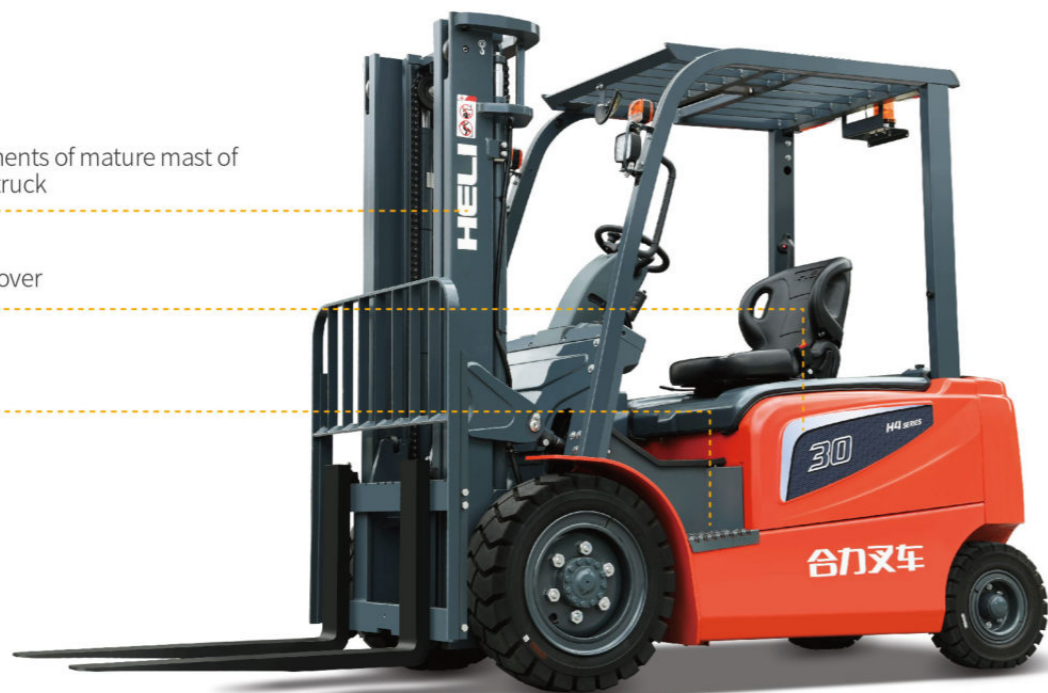

## Good lateral stability of the whole truck and guaranteed safety during operation

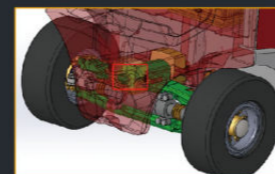

High rotation point steering axle

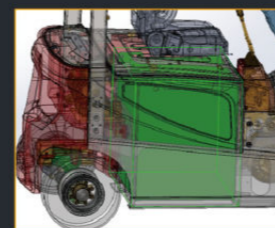

Middle and sink layout of the battery



## Good heat dissipation

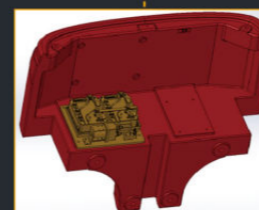

The electric control is placed on the counterweight

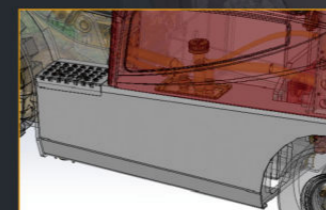

Side mounted welded oil tank

## Test verification



### Rain test

Simulate the operation under 15min rainstorm, reach IPx4 protection grade, and meet the needs of outdoor operation.



### Cold storage test

The whole truck can run continuously after 6 hours of alternating operation in the -20 °C cold storage and 12 hours of parking in the cold storage.



### Vehicle vibration test

The vibration frequency of the whole truck is tested to optimize and improve the operating comfort.



### Reliability endurance test

800 hour strengthening of the whole truck (including climbing, rain, bumpy road, etc.).

# Intelligent security

Intelligent control and protection improve the safety of drivers.

- Dual core controller
- OPS protection  
(standard driving OPS / optional hydraulic OPS)
- Hydraulic burst protection, forward tilting self-locking protection
- Electrical multiple protection  
(short circuit protection, overheat protection, low power protection, sequence protection)
- Parking safety reminder
- Reminder through slow sliding on ramp
- Turning automatic deceleration (optional)



- Flexible battery charging mode (can be charged with the truck or replaced)
- Pump, pump motor, controller and other main electrical components are located on the counterweight, which is convenient for maintenance.
- Friendly interface

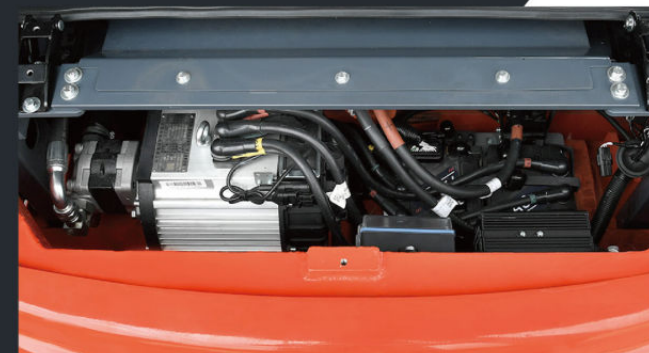

ADMIN

1.SW MONITOR	7.P.M.SET
2.OPERATE MONITOR	8.BDI SET
3.TEMP MONITOR	9.STEER SET
4.CUR MONITOR	10.T.M.CUR SET
5.USER.SET	11.T.S.CUR SET
6.T.M. SET	12.P.M.CUR SET



## Convenient maintenance

More convenient maintenance operation improves the maintenance efficiency of after-sale services.

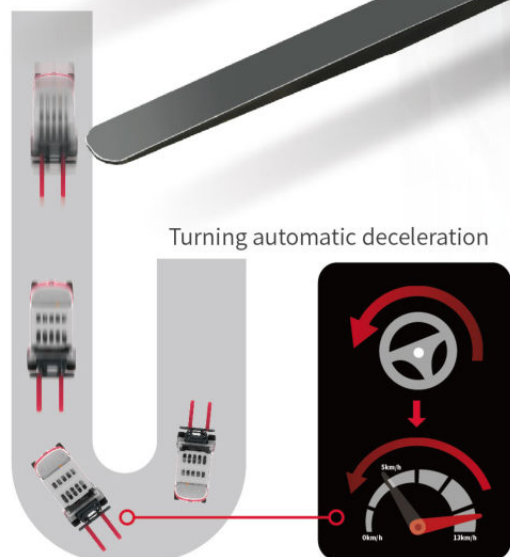

Manufacturer and Technical Data (Table 1)

Characteristics						
1.01	Manufacturer			<b>HELI</b>		
1.02	Model		CPD15	CPD18	CPD15	CPD20
1.03	Configuration number		A3H4-M/ A5H4-M	A3H4-M/ A5H4-M	A5H4-S	A5H4-S
1.04	Rated capacity	Q	kg	1500	1800	2000
1.05	Load center distance	c	mm		500	
1.06	Power mode			Battery		
1.07	Driving mode			Seated		
1.08	Front overhang	x	mm	409		414
1.09	Wheelbase	y	mm	1475		
Weight						
2.01	Total weight (with/without battery)		kg	3125/2365	3175/2415	3050/2350
2.02	Axle load (laden,front/rear)		kg	3963/662	4431/544	3934/616
2.03	Axle load (unladen,front/rear)		kg	1547/1578	1540/1635	1518/1532
Tyres						
3.01	Tyre type			Pneumatic tyre		
3.02	Tyre size,front			6.50-10-10PR		
3.03	Tyre size,rear			16×6-8-10PR		
3.04	Wheels,number front/rear (x=driven wheels)			2/2		
3.05	Tread, front	b10	mm	934		
3.06	Tread, rear	b11	mm	920		
Dimensions						
4.01	Mast tilt angle (forward/backward)	$\alpha/\beta$	°	6/8		
4.02	Height (mast lowered)	h1	mm	1995		
4.03	Free lifting height	h2	mm	155		
4.04	Lifting height (standard)	h3	mm	3000		
4.05	Max. height,extended (with backrest)	h4	mm	4014		
4.06	Height of overhead guard	h6	mm	2130		
4.07	Seat height relating to SIP (to ground)	h7	mm	1125		
4.08	Towing coupling height	h10	mm	250		
4.09	Overall length (with fork)	l1	mm	3120		3125
4.10	Overall length (without fork)	l2	mm	2200		2205
4.11	Overall width	b1	mm	1120		
4.12	Fork carriage,according to ISO2328	s/e/l	mm	2A		
4.13	Fork size:thickness x width x length			35×100×920		40×100×920
4.14	Distance across fork-arms, Max./Min.	b5	mm	960/200		
4.15	Distance across fork-arms, Max./Min.	m1	mm	100		
4.16	Ground clearance (center of wheelbase)	m2	mm	95		
4.17	Right angle stacking aisle width for pallet 1000×1200mm (the side of 1200mm is placed across the forks.)	Ast	mm	3575		3580
4.18	Right angle stacking aisle width for pallet 800×1200mm (the side of 1200mm is placed along the forks.)	Ast	mm	3770		3775
4.19	Min. outside turning radius	Wa	mm	1920		
Performance Data						
5.01	Travel speed (laden/unladen)		km/h	14.5/15	14.5/15	12/13
5.02	Lift speed (laden/unladen)		m/s	0.320/0.440	0.290/0.440	0.290/0.400
5.03	Lowering speed (laden/unladen)		m/s			0.400/0.400
5.04	Max.drawbar pull (laden/unladen)		N	10200/9700	10200/9800	10200/9800
5.05	Max.gradeability (laden/unladen)		%	17/27	15/26	15/23
5.06	Acceleration time(10 m)(laden/unladen)		s	5.5/5.2	5.6/5.3	6.0/5.7
Battery						
6.01	Battery,according to DIN			43536A		
6.02	Battery voltage/Capacity (K5)		V/Ah	48/480	48/480	48/400
6.03	Battery weight		kg	760	760	700
Motor and controller						
7.01	Driving motor powering (S2-60min)		kW	8		
7.02	Lifting motor powering (S3-15%)		kW	10.6		
7.03	Driving motor controlling mode			MOSFET/AC		
7.04	Lifting motor controlling mode			MOSFET/AC		
Addition data						
8.01	Service brake/Parking brake			Hydraulic/Mechanical		
8.02	Operating pressure for attachments		Mpa	16		

Manufacturer and Technical Data (Table 2)

Characteristics						
1.01	Manufacturer			<b>HELI</b>		
1.02	Model			CPD20	CPD25	CPD20
1.03	Configuration number			A3H4-M/ A5H4-M	A3H4-M/ A5H4-M	A5H4-S
1.04	Rated capacity	Q	kg	2000	2500	2000
1.05	Load center distance	c	mm		500	
1.06	Power mode			Battery		
1.07	Driving mode			Seated		
1.08	Front overhang	x	mm	460		
1.09	Wheelbase	y	mm	1660		
Weight						
2.01	Total weight (with/without battery)		kg	4030/3100	4190/3260	3940/3100
2.02	Axle load (laden,front/rear)		kg	5300/730	6010/680	5220/720
2.03	Axle load (unladen,front/rear)		kg	2050/1980	2140/2150	2030/1930
Tyres						
3.01	Tyre type			Pneumatic tyre		
3.02	Tyre size,front			7.00-12-14PR		
3.03	Tyre size,rear			18×7-8-14PR		
3.04	Wheels,number front/rear (x=driven wheels)			2/2		
3.05	Tread, front	b10	mm	970		
3.06	Tread, rear	b11	mm	960		
Dimensions						
4.01	Mast tilt angle (forward/backward)	$\alpha/\beta$	°	6/10		
4.02	Height (mast lowered)	h1	mm	2000		
4.03	Free lifting height	h2	mm	165		
4.04	Lifting height (standard)	h3	mm	3000		
4.05	Max. height,extended (with backrest)	h4	mm	4320		
4.06	Height of overhead guard	h6	mm	2170		
4.07	Seat height relating to SIP (to ground)	h7	mm	1154		
4.08	Towing coupling height	h10	mm	300		
4.09	Overall length (with fork)	l1	mm	3354	3504	3354
4.10	Overall length (without fork)	l2	mm	2434		
4.11	Overall width	b1	mm	1180		
4.12	Fork carriage,according to ISO2328	s/e/l	mm	2A		
4.13	Fork size:thickness x width x length			40×122×920	40×122×1070	40×122×920
4.14	Distance across fork-arms, Max./Min.	b5	mm	1030/250		
4.15	Distance across fork-arms, Max./Min.	m1	mm	100		
4.16	Ground clearance (center of wheelbase)	m2	mm	125		
4.17	Right angle stacking aisle width for pallet 1000×1200mm (the side of 1200mm is placed across the forks.)	Ast	mm	3753		3753
4.18	Right angle stacking aisle width for pallet 800×1200mm (the side of 1200mm is placed along the forks.)	Ast	mm	3953		3953
4.19	Min. outside turning radius	Wa	mm	2140		
Performance Data						
5.01	Travel speed (laden/unladen)		km/h	14.5/15	14.5/15	12/13
5.02	Lift speed (laden/unladen)		m/s	0.320/0.440	0.290/0.440	0.290/0.400
5.03	Lowering speed (laden/unladen)		m/s			0.360/0.460
5.04	Max.drawbar pull (laden/unladen)		N	13600/13000	14000/13300	13600/13000
5.05	Max.gradeability (laden/unladen)		%	17/26	15/25	15/25
5.06	Acceleration time(10 m)(laden/unladen)		s	5.9/5.0	6.1/5.0	6.0/5.3
Battery						
6.01	Battery,according to DIN			43536A		
6.02	Battery voltage/Capacity (K5)		V/Ah	48/600	48/600	48/500
6.03	Battery weight		kg	930	930	840
Motor and controller						
7.01	Driving motor powering (S2-60min)		kW	11		
7.02	Lifting motor powering (S3-15%)		kW	12		
7.03	Driving motor controlling mode			MOSFET/AC		
7.04	Lifting motor controlling mode			MOSFET/AC		
Addition data						
8.01	Service brake/Parking brake			Hydraulic/Mechanical		
8.02	Operating pressure for attachments		Mpa	16		

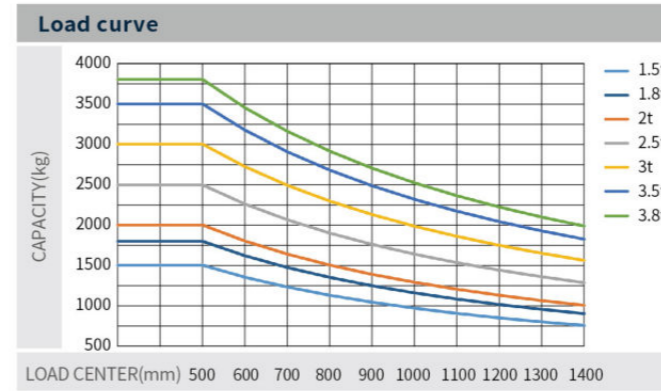
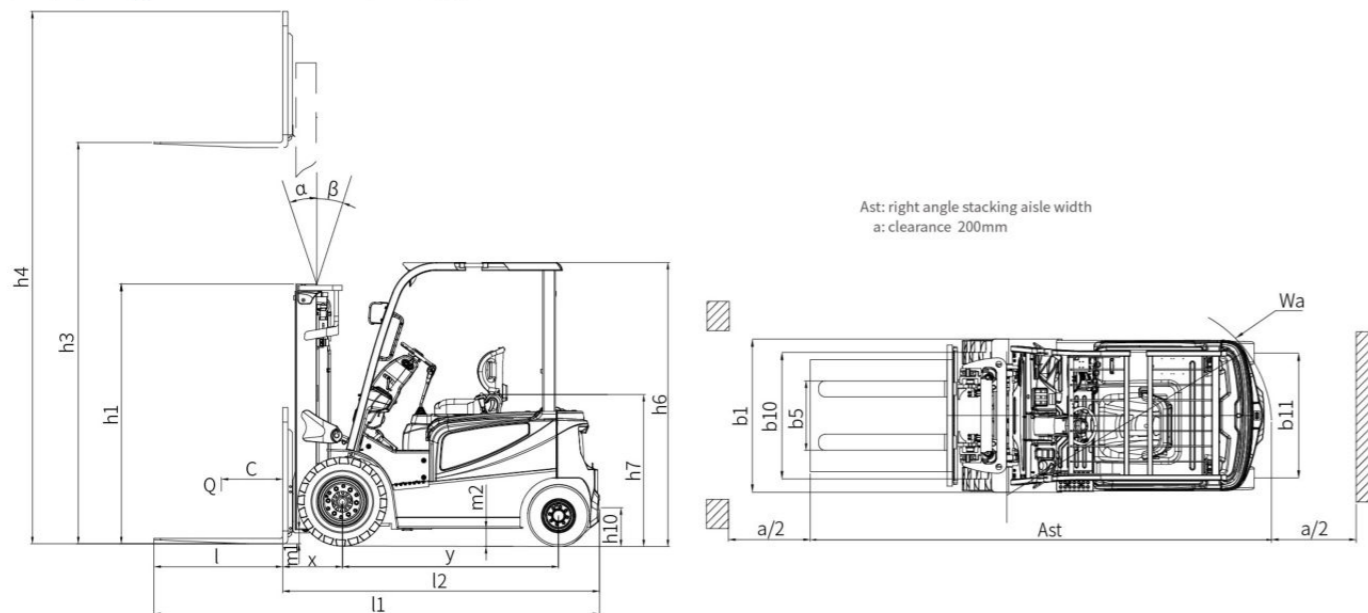

**Note:**  
The vertical axis stands for load capacity and the horizontal axis stands for load center which is calculated from the front surface of the forks to the gravity of the standard load. the standard load means a cubic with 1000mm edge length. When mast is tilted forward, using non-standard forks or loading large goods, the load capacity will be reduced. The load capacity of standard mast at different load center can be known from this load chart.



## 3t/3.5t/3.8t Mast parameters

Mast type	Mast model	Max.lifting height (mm)	Load capacity (kg)					Height (mm)			Free lift height (with backrest) (mm)			Service weight (kg)					Mast tilt angle α/β (°)	
			3t-M	3t-S	3.5t-M	3.5t-S	3.8t	3t	3.5t	3.8t	3t	3.5t	3.8t	3.0t-S	3.0t-M	3.5t-S	3.5t-M	3.8t-S		
2-stage standard Mast	M200	2000	3000	3000	3500	3500	3800	1570	1620	1680	155	160	160	4899	4804	5204	5004	5504	6/10	
	M250	2500	3000	3000	3500	3500	3800	1820	1870	1930	155	160	160	4947	4852	5257	5057	5557	6/10	
	M300	3000	3000	3000	3500	3500	3800	2070	2120	2180	155	160	160	4995	4900	5310	5110	5610	6/10	
	M330	3300	3000	3000	3500	3500	3800	2220	2270	2330	155	160	160	5024	4929	5342	5142	5642	6/10	
	M350	3500	3000	3000	3500	3500	3800	2320	2370	2430	155	160	160	5043	4948	5363	5163	5663	6/10	
	M370	3700	3000	3000	3500	3500	3800	2420	2470	2530	155	160	160	5062	4967	5384	5184	5684	6/6	
	M400	4000	3000	2850	3500	3150	3700	2620	2670	2730	155	160	160	5142	5047	5468	5268	5768	6/6	
	M425	4250	2850	2750	3300	3050	3550	2745	2795	2855	155	160	160	5166	5071	5494	5294	5794	6/6	
	M450	4500	2850	2800	3400	3150	3650	2870	2920	2980	155	160	160	5190	5095	5521	5321	5821	6/6	
	M500	5000	2850	2700	3350	3100	3600	3120	3170	3230	155	160	160	5238	5143	5574	5374	5874	6/6	
	M550	5500	2850	2650	3300	3050	3500	3420	3470	3530	155	160	160	5336	5241	5678	5478	5978	6/6	
M600	6000	2850	2650	3300	3050	3500	3670	3720	3780	155	160	160	5384	5289	5731	5531	6031	6/6		
2-stage full free mast	ZM200	2000	3000	3000	3500	3500	3800	1570	1620	1680	340	443	503	4927	4832	5228	5028	5528	6/10	
	ZM250	2500	3000	3000	3500	3500	3800	1820	1870	1930	590	693	753	4977	4882	5281	5081	5581	6/10	
	ZM300	3000	3000	3000	3500	3500	3800	2070	2120	2180	840	943	1003	5027	4932	5335	5135	5635	6/10	
	ZM330	3300	3000	3000	3500	3500	3800	2220	2270	2330	990	1093	1153	5059	4964	5368	5168	5668	6/10	
	ZM350	3500	3000	3000	3500	3500	3800	2320	2370	2430	1090	1193	1253	5079	4984	5389	5189	5689	6/10	
	ZM370	3700	3000	3000	3500	3200	3800	2420	2470	2530	1190	1293	1353	5099	5004	5410	5210	5710	6/6	
	ZM400	4000	3000	2850	3500	3200	3700	2620	2670	2730	1390	1493	1553	5177	5082	5490	5290	5790	6/6	
	ZM425	4250	2850	2750	3300	3050	3500	2745	2795	2855	1515	1618	—	5203	5108	5517	5317	—	6/6	
	ZM450	4500	2850	2800	3400	3150	3600	2870	2920	2980	1640	1743	—	5231	5136	5546	5346	—	6/6	
	ZM500	5000	2850	2700	3350	3100	3600	3120	3170	3230	1890	1993	—	5285	5190	5602	5402	—	6/6	
	ZM550	5500	2850	2650	3300	3050	3500	3420	3470	3530	2190	2293	—	5384	5289	5705	5505	—	6/6	
ZM600	6000	2850	2650	3300	3050	3500	3670	3720	3780	2440	2543	—	5437	5342	5761	5561	—	6/6		
3-stage full free mast	ZSM360	3600	3000	2850	3500	3250	3800	1870	1870	1930	640	640	693	5138	5043	5421	5221	5724	6/6	
	ZSM400	4000	3000	2750	3500	3100	3700	2020	2020	2055	790	790	843	5179	5084	5462	5262	5765	6/6	
	ZSM435	4350	2850	2550	3200	2950	3500	2120	2120	2180	890	890	943	5208	5113	5491	5291	5794	6/6	
	ZSM450	4500	2850	2450	3050	2850	3400	2170	2170	2230	940	940	993	5223	5128	5506	5306	5809	6/6	
	ZSM470	4700	2850	2400	3000	2850	3100	2230	2230	2295	1000	1000	1053	5241	5146	5524	5324	5827	6/6	
	ZSM480	4800	2850	2350	2950	2850	3100	2270	2270	2330	1040	1040	1093	5251	5156	5534	5334	5837	6/6	
	ZSM500	5000	2850	2300	2900	2850	3000	2370	2370	2430	1140	1140	1193	5278	5183	5561	5361	5864	6/6	
	ZSM540	5400	2850	2250	2850	2800	3000	2470	2470	2555	1240	1240	1293	5308	5213	5591	5391	5894	6/6	
	ZSM600	6000	2850	2200	2800	2800	2900	2670	2670	2780	1440	1440	1493	5412	5317	5693	5493	5998	6/6	
	ZSM650	6500	2850	2150	2750	2750	2850	—	2870	2870	—	1640	1640	—	5467	5372	5750	5550	—	6/6
	ZSM700	7000	2850	2100	2700	2700	—	3045	3045	—	1815	1815	—	5517	5422	5800	5600	—	6/6	

Note: \*Indicates the rated load capacity of the front wheel with twin tyres; When the front wheels of 3-3.5t are twin tyres (pneumatic tyres) and twin tyres (solid tyres), the service weight is increased by 140kg and 208kg respectively according to the table data; When the front wheels of 3.8t are twin tyres (pneumatic tyres) and twin tyres (solid tyres), the service weight is increased by 103kg and 251kg respectively according to the table data.  
2-stage full free mast: 3t: When there is no backrest, the free lifting height increases by 477mm; 3.5t: When there is no backrest, the free lifting height increases by 407mm; 3.8t: When there is no backrest, the free lifting height increases by 407mm;  
3-stage full free mast: 3t: When there is no backrest, the free lifting height increases by 427mm; 3.5-3.8t: When there is no backrest, the free lifting height increases by 407mm.

## Optional item

Optional item	Model	S	M	
Basic items	Pneumatic tyre*	●	●	
	Solid tyre	○	○	
	Single tyre (front wheel)	●	●	
	Twin tyre (front wheel)**	○	○	
	Two piece valve	●	●	
	Three or four piece valve	○	○	
	Basic type: 3M lifting height mast	●	●	
	Other type and other height seriesmast***	○	○	
	Standard series fork	●	●	
	Non standard series forks and attachments	○	○	
	Standard exterior color (blue grey + Heli red)	●	●	
	Other exterior colors (customized)	○	○	
	Safety items	Turning speed limit	○	○
		Reversing armrest with horn switch	○	●
		Overspeed 5km / h alarm	○	○
		Overspeed 8km / h alarm	○	○
Overspeed 10km / h alarm		○	○	
Travelling + lifting + tilting + equipped with OPS function (without lowering)		●	●	
Full set of OPS functions		○	○	
Seat belt switch		○	○	
Multi way valve overload		●	●	
Dry powder fire extinguisher (0.5kg)		○	○	
Dry powder fire extinguisher (2kg)		○	○	
Carbon dioxide fire extinguisher (2kg)		○	○	
Reversing buzzer		●	●	
Reversing Chinese speaker		○	○	
No universal key		●	●	
With universal key		○	○	
Comfort items		Electronic lifting upper buffer	○	○
	Central wide-angle rearview mirror	●	●	
	Both side rear-view mirrors + center wide-angle rear-view mirror	○	○	
	Reversing radar (4 probes)	○	○	
	Reversing image (1 Camera + 4 radar probes)	○	○	
	Semi enclosed seat	●	●	
	Fully suspended seat	○	○	
	Instrument panel with 1 USB interface (5V / 1A)	○	●	
	Steering wheel starts steering	○	○	
Synchronous steering	○	○		
Steering wheel with handle ball	●	●		
Steering wheel without handle ball	○	○		
electric fan	○	○		
Cab / Windshield / Air conditioner / Heater	panel mounted cab (including fan + wiper)	○	○	
	Heater	○	○	
	Single cooling air conditioner	○	○	
	Single cooling air conditioner + heater	○	○	
	Front windshield (including wiper)	○	○	
	Rear windshield	○	○	
Non standard overhead guard	Top windshield (excluding fan)	○	○	
	50mm increased of overhead guard height	○	○	
	Overhead guard (with protective net)	○	○	
	LED rear work light (1)	○	○	
Lights	Rear LED red / Blue spotlight (1)	○	○	
	Rear and lateral red / blue bar lights	○	○	
	Fixed LED flashing warning light	○	●	
	Fixed LED rotary warning lamp	○	○	
	Fixed LED rotary buzzer warning light	○	○	
	Others	Metric thread	●	●
		Tilt cylinder jacket	○	○
Steering cylinder jacket		○	○	
REMA power connector		●	●	
Domestic battery		●	●	
GS battery		○	○	
HOPPECKE battery		○	○	
FAAM battery		○	○	
(battery) with automatic water replenishment	○	○		
FICS standard type (for China)	○	○		

Note:

\*● Standard ; ○ Optional ;

Some non-standard options need to be customized. Please consult local sales personnel or product development technicians before purchasing.

\*\*3-3.8t rear wheel is equipped with solid tyre as standard.

\*\*\*The small 2t truck is not equipped with twin tyres.

\*\*\*There are restrictions on the type and height of small 2t and 3.8t mast. See the table of mast parameters for details.